

Data sheet and installation information

1. Machine configuration and overall dimensions



e4 / e4m



e4 / e4m / cup heater



e4m / fridge

e4	e4	e4m	e4 cup heater	e4m cup heater	e4m fridge
w/h/d mm	560/713/600	560/713/600	840/713/600	840/713/600	840/713/600
w/h/d (inch)	(22 / 27.9 / 23.6)	(22 / 27.9 / 23.6)	(33 / 27.9 / 23.6)	(33 / 27.9 / 23.6)	(33 / 27.9 / 23.6)
weight kg	90	94	115	119	124
weight (lb)	198	207	253	262	273

Capacity

Coffee	350 Espresso / hour at 23s extraction time 4 Espresso at the same time
Steam	Manual steam, continuous steam supply Autosteam, temperature controlled Everfoam, fully automatic frothing (option)
Hot Water	150 hot water units / hour, 200ml (6.8 oz US)
Milk system	350 Cappuccino / hour

Technical data

Brew chamber	2 x up to 24g
Grinding	2 x drive ceramic grinder disk
User Interface	2 x 8" color touch screen
Bean hoppers	2 x 1.5kg (3.3 lb)
Coffee spout hgt	65mm to 165mm (2.55 to 6.49 inch)
Interface	USB, SD-Card, Ethernet, Serial, RS-232, CCI
Standby mode	less than 2W
Steam boiler size	e4: 8 litre (2.11 gal US) e4m: 5.6 litre (1.48 gal US)
Coffee boiler size	2 x 1.5 Litre (2 x 0.39 gal US)
Lighting concept	Front panel full color LED

Power requirement

Single-phase	1/N/PE, 220-240V~, 50/60Hz, 25A, 5.8kW
Two-phases	2/PE, 200-210V~, 50/60Hz, 30A, 4.9kW
Three-phases	3/N/PE, 380-420V~, 50/60Hz, 15A, 9.6kW
Three-phases (Triangle)	3/PE, Δ 220-230V~, 50/60Hz, 20A, 5.8kW

Water Connection

Water	G3/8" female, 2.5 - 4 bar,
Water hose	2 m length (78.7 inch)
Drain	Self priming (see drawing rear side)

Water quality	Total hardness: 5 - 8°dGH (89-142 ppm) Carbonate hardness: max. 6°dKH (107 ppm) pH value: ideal 7.0 - 7.2
---------------	---

Fridge

4 litre container (1.05 gal US)
Milk tube length max 1.5m (59 inch)

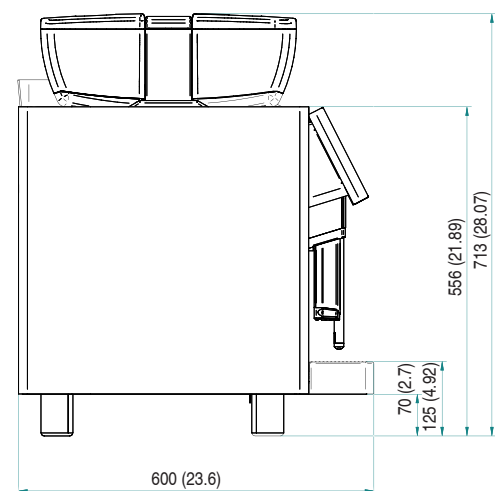
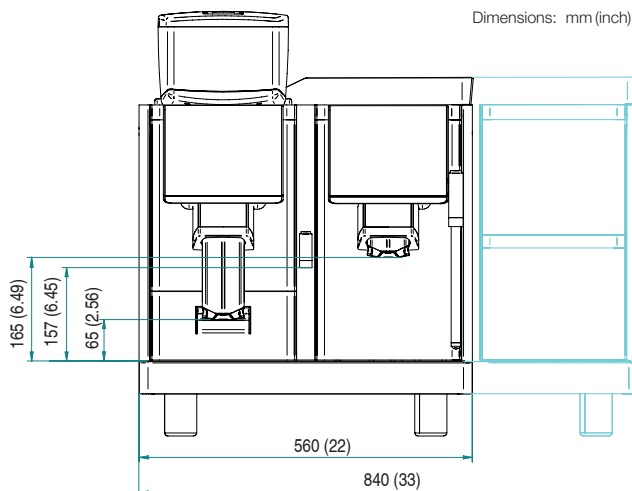

true espresso with a touch

2. Prior to the installation, READ SAFETY INSTRUCTIONS

- Check water quality
- Define filter type and size and check space inside counter
- If no descaling cartridge is used, install carbon filter as minimum
- Check required desk for machine
- Check counter cut out
- Check water supply installation
- Check power supply installation
- Check all with customer on site
- Make sure original coffee is available
- Make sure cold milk is available
- Check drinks recipes and cup sizes
- Organize milk pitcher

3. After installation

- Instruct staff using Quick reference card
- Fill in installation warranty sheet and send it back to Eversys

4. Desk preparation

mm (inch)

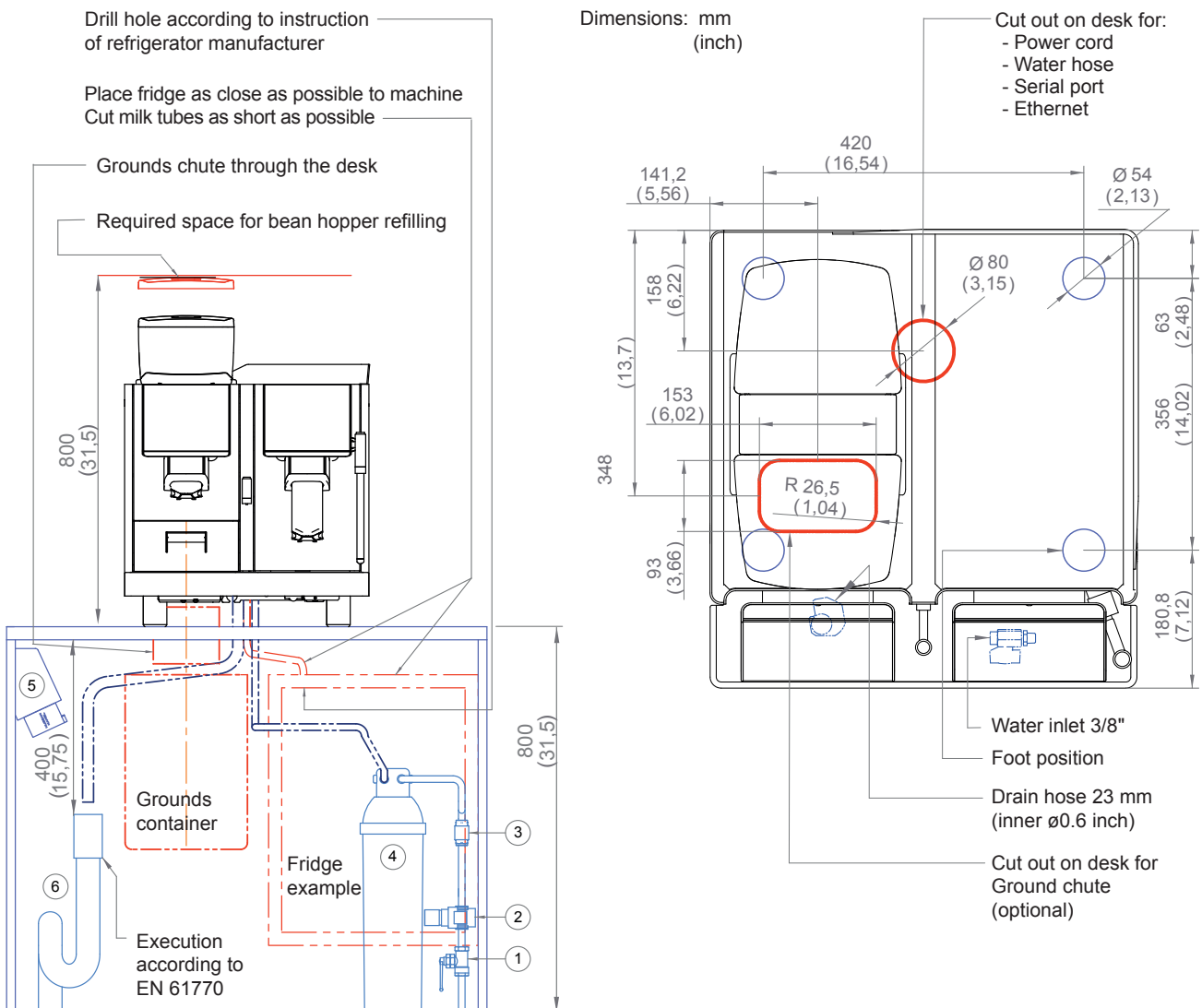

1. Main water inlet
2. Pressure reducer output 3 bar (43,5 psi)
3. Check valve
4. Descaling cartridge or carbon filter as minimum
5. Electrical socket according to local standard
6. Drain with syphon, top end min. 56mm diameter (2.2 inch)